

# DATA SHEET

Part No.	AN13301A
Package Code No.	QFP048-P-1212C

Contents

- Function ..... 3
- Applications ..... 3
- Package ..... 3
- Block Diagram ..... 4
- Pin Descriptions ..... 5
- Absolute Maximum Ratings ..... 6
- Operating Supply Voltage Range ..... 6

# AN13301A

## Silicon Monolithic Bi - CMOS IC

### ■ Function

- Video signal output interface for D - terminal

### ■ Applications

- STB

### ■ Package

- 4Directions - 48Pin Plastic Package ( QFP Type )

■ Block Diagram

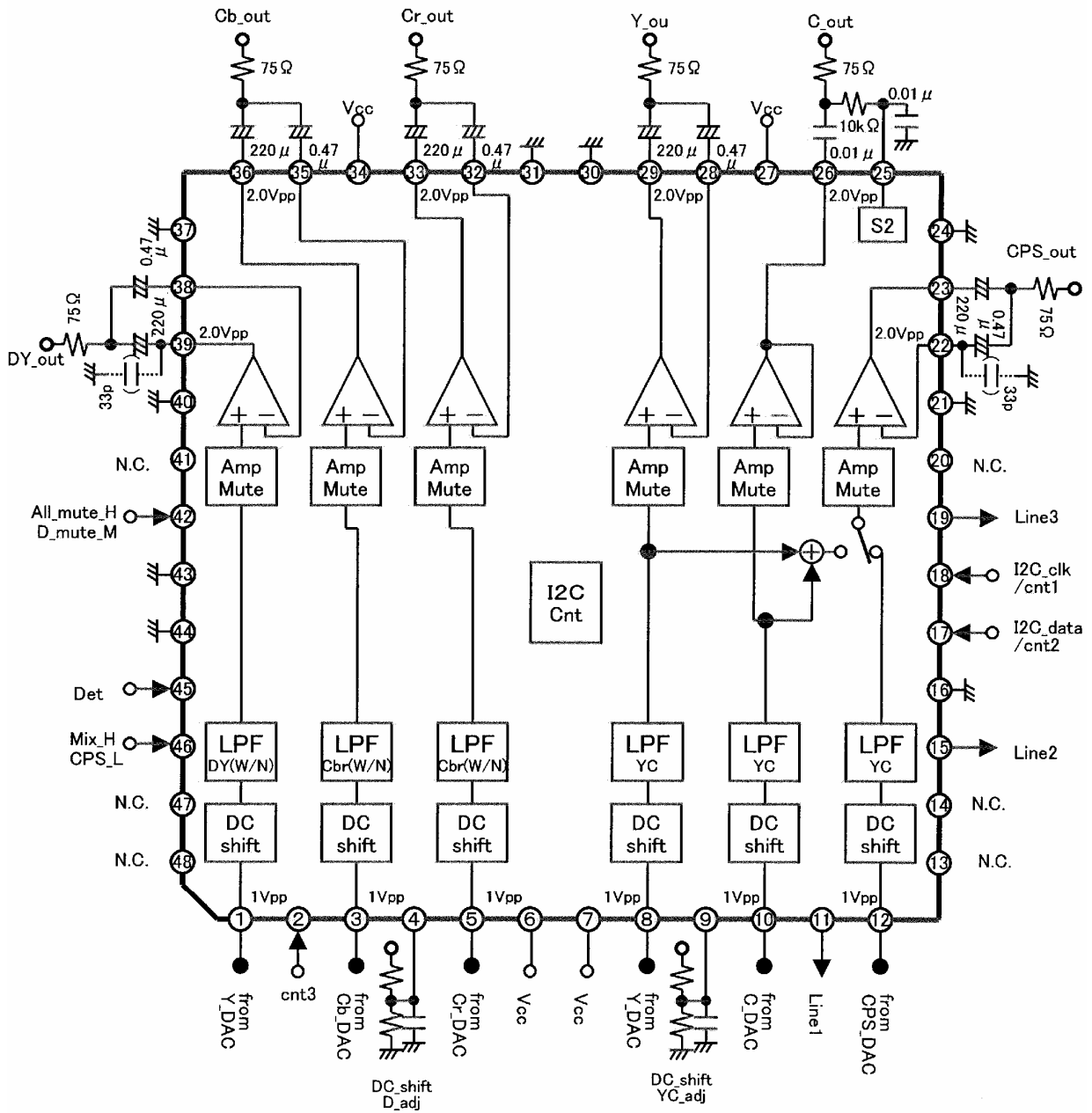

## ■ Pin Descriptions

Pin No.	Function	Impedance	Pin No.	Function	Impedance
1	DY input	Hi - Z	25	S2 output	Lo - Z
2	ctrl 3 input	Hi - Z	26	AC output	E. F.
3	Cb input	Hi - Z	27	V <sub>CC</sub>	—
4	DC shift	Hi - Z	28	AY Sag compensation	30 kΩ
5	Cr input	Hi-Z	29	AY output	E. F.
6	V <sub>CC</sub>	—	30	GND	—
7	V <sub>CC</sub>	—	31	GND	—
8	AY input	Hi - Z	32	Cr Sag compensation	30 kΩ
9	DC shift	Hi - Z	33	Cr output	E. F.
10	AC input	Hi - Z	34	V <sub>CC</sub>	—
11	Line 1 output	Lo - Z	35	Cb Sag compensation	30 kΩ
12	CPS input	Hi - Z	36	Cb output	E. F.
13	N. C.	—	37	GND	—
14	N. C.	—	38	DY sag compensation	30 kΩ
15	Line 2 output	Lo - Z	39	DY output	E. F.
16	GND	—	40	GND	—
17	I <sup>2</sup> C data / ctrl 2 input	Hi - Z	41	N. C.	—
18	I <sup>2</sup> C clock / ctrl 2 input	Hi - Z	42	Mute input	Hi - Z
19	Line 3 output	Lo - Z	43	( GND )	—
20	N. C.	—	44	GND	—
21	GND	—	45	Det input	Hi - Z
22	CPS Sag compensation	30 kΩ	46	Mix / CPS input	Hi - Z
23	CPS output	E. F.	47	N. C.	—
24	GND	—	48	N. C.	—

### ■ Absolute Maximum Ratings

No.	Parameter	Symbol	Rating	Unit	Note
1	Storage temperature	$T_{stg}$	-55 to +125	°C	*1
2	Operating ambient temperature	$T_{opr}$	-20 to +70	°C	*1
3	Operating ambient atmospheric pressure	$P_{opr}$	$1.013 \times 10^5 \pm 0.61 \times 10^5$	Pa	
4	Operating constant gravity	$G_{opr}$	9 810	m/s <sup>2</sup>	
5	Operating shock	$S_{opr}$	4 900	m/s <sup>2</sup>	
6	Supply voltage	$V_{CC}$	$V_{CC}$ 5.5	V	
7	Supply current	$I_{CC}$	$I_{CC}$ —	mA	
8	Power dissipation	$P_D$	468	mW	*2

Note) \*1 : Expect for the operating ambient temperature and storage temperature , all ratings are for  $T_a = 25^\circ\text{C}$ .

Note) \*2 : The above power dissipation shows the package dissipation of the IC without heat sink at  $T_A = 70^\circ\text{C}$   
Refer to the  $P_d - T_a$  characteristic curve in page 21.

### ■ Operating Supply Voltage Range

Operating supply voltage range	$V_{CC}$	4.75 V to 5.25 V
--------------------------------	----------	------------------

## Request for your special attention and precautions in using the technical information and semiconductors described in this book

- (1) If any of the products or technical information described in this book is to be exported or provided to non-residents, the laws and regulations of the exporting country, especially, those with regard to security export control, must be observed.
- (2) The technical information described in this book is intended only to show the main characteristics and application circuit examples of the products, and no license is granted under any intellectual property right or other right owned by our company or any other company. Therefore, no responsibility is assumed by our company as to the infringement upon any such right owned by any other company which may arise as a result of the use of technical information described in this book.
- (3) The products described in this book are intended to be used for standard applications or general electronic equipment (such as office equipment, communications equipment, measuring instruments and household appliances).  
Consult our sales staff in advance for information on the following applications:
  - Special applications (such as for airplanes, aerospace, automobiles, traffic control equipment, combustion equipment, life support systems and safety devices) in which exceptional quality and reliability are required, or if the failure or malfunction of the products may directly jeopardize life or harm the human body.
  - Any applications other than the standard applications intended.
- (4) The products and product specifications described in this book are subject to change without notice for modification and/or improvement. At the final stage of your design, purchasing, or use of the products, therefore, ask for the most up-to-date Product Standards in advance to make sure that the latest specifications satisfy your requirements.
- (5) When designing your equipment, comply with the range of absolute maximum rating and the guaranteed operating conditions (operating power supply voltage and operating environment etc.). Especially, please be careful not to exceed the range of absolute maximum rating on the transient state, such as power-on, power-off and mode-switching. Otherwise, we will not be liable for any defect which may arise later in your equipment.
  - Even when the products are used within the guaranteed values, take into the consideration of incidence of break down and failure mode, possible to occur to semiconductor products. Measures on the systems such as redundant design, arresting the spread of fire or preventing glitch are recommended in order to prevent physical injury, fire, social damages, for example, by using the products.
- (6) Comply with the instructions for use in order to prevent breakdown and characteristics change due to external factors (ESD, EOS, thermal stress and mechanical stress) at the time of handling, mounting or at customer's process. When using products for which damp-proof packing is required, satisfy the conditions, such as shelf life and the elapsed time since first opening the packages.
- (7) This book may be not reprinted or reproduced whether wholly or partially, without the prior written permission of Matsushita Electric Industrial Co., Ltd.